



红太阳贴片电解电容

深圳市玮硕实业有限公司

Shenzhen Weishuo (Rubysun) Industrial Technology Co., Ltd.

规格承认书

客户名称:					
产品名称:	RUBYSUN VT 470UF 25V 10*10.5MM				
产品类别:	贴片铝电解电容器	产品系列:	VT		
产品编码:	VT1E471MCRG10	工作温度:	-40°C~105°C		
额定电压:	25V	容量范围:	376~564UF	使用寿命:	2000H

主办工程栏:

核准	审核	制作	发行日期
黄涛	李俊	郝漫	2024-08-08

客户承认栏:

--	--	--	--

地址: 深圳市龙华区观澜章阁市场尚之佳创业园 A 栋 3 楼

电话: 86-755-83227006

传真: 86-755-21074158

红太阳贴片电解电容产品编码规则

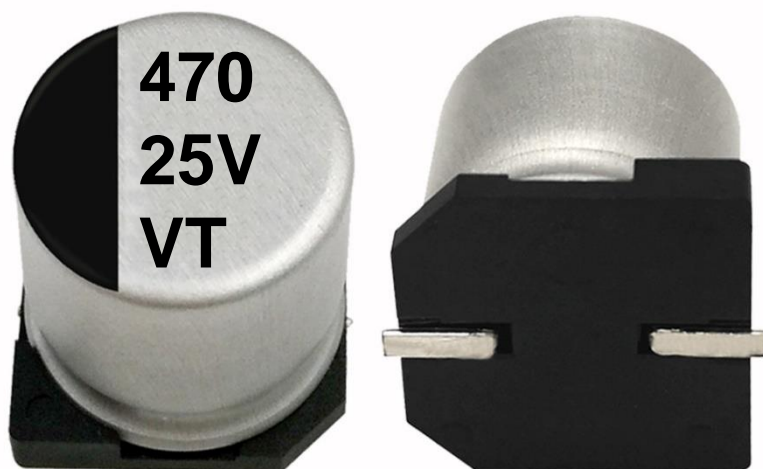

系列 容量 电压
TYPE: VT 47UF 50V



系列 电压 容量 允差 类型 引线 直径 高度
P/N: VT1H470MCRE77



LOT: 211102WS060109 日期



CUSTOMR: 深圳市伟创立电子有限公司 客户名称

直径 高度
SIZE: 6.3*7.7MM



容量 电压
47 UF 50 V

QTY: 1000 PCS 包装数量



PO: FWD20211102-0186 客户订单号

详细参数



品牌商标 系列
RUBYSUN VT

RoHS Compliant

P/N: 01003856 客户物料编码

标签	P/N: 物料编码		QTY: 包装数量		LOT: 生产日期		TYPE: 详细参数	
系列	VT-2000H 标准品		VD-5000H 高频低阻		CS-2000H 标准品		CK-2000H 标准品	
电压	0J-6.3V	1A-10V	1C-16V	1E-25V	1V-35V	1H-50V	1J-63V	2A-100V
容量	0R1-0.1UF	010-1UF	100-10UF	101-100UF	102-1000UF	220-22UF	221-220UF	471-470UF
允差	K-±10%	M-±20%						
类型	C-贴片封装				引线		R-编带卷盘	
直径	3-S	4-C	5-D	6.3-E	8-F	10-G	12.5-I	
高度	5.4-54	5.8-58	6.2-62	7.7-77	10.5-10	12.5-12	13.5-13	16.5-16
包装	4*5.4	5*5.4	6.3*5.4	6.3*7.7	8*10.5	10*10.5	12.5*13.5	16*16.5
	2000PCS	1000PCS	1000PCS	1000PCS	500PCS	500PCS	200PCS	125PCS
箱装	小箱-5000PCS		中箱-10000PCS		大箱-20000PCS			

产品规格书 RUBYSUN PRODUCT SPECIFICATION

序号 No	目录 INDEX	页 page
1	概述 SCOPE	4
2	外形尺寸图及尺寸表 Case size table	4
3	技术性能 SPECIFICATIONS	5
4	称电容量、额定电压、额定纹波电流与外形尺寸对应表 Nominal capacitance, rated voltage, rated ripple current and case size table	6~7
5	构造图及材料表 Frame drawing and materials	8
6	试验方法及要求 TESTS	9~12
7	标志 Marking	13
8	片式铝电解电容的编带 V- Chip Type Aluminum Electrolytic Capacitors	13
9	环保 ROHS	14

产品规格书 RUBYSUN PRODUCT SPECIFICATION

一、概述 SCOPE

本产品规格书适用于深圳市玮硕实业有限公司生产的 VT 型片式铝电解电容器产品。

The product specification is adapted to series VT V-CHIP Aluminum Electrolytic Capacitors of Shenzhen Weishuo (Rubysun) Industrial Technology Co., Ltd

二、外形图及尺寸表 Case size table

1. $\phi 4 \sim \phi 6.3$

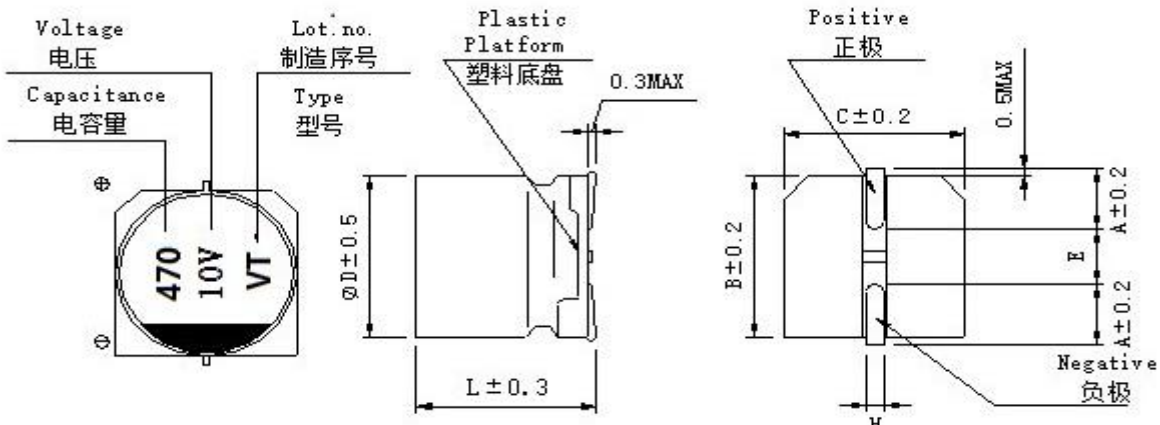

2. $\phi 8 \sim \phi 18$

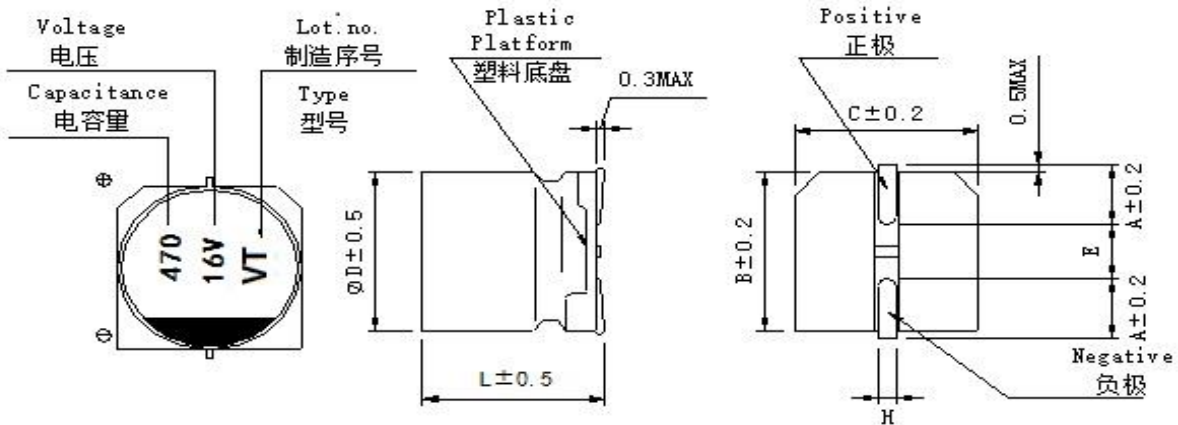

3. 单位:MM

ITEM	4 x 5.4	5 x 5.4	6.3 x 5.4	6.3 x 7.7	6.3 x 10.5	8 x 10.5	8 x 12.5	10 x 10.5	10 x 12.5	12.5 x 13.5	12.5 x 16.5	16 x 16.5	18 x 16.5	18 x 21.5	
A	1.8	2.1	2.4	2.4	2.4	2.9	2.9	3.2	3.2	4.8	4.8	5.8	6.8	6.8	
B	4.3	5.3	6.6	6.6	6.6	8.3	8.3	10.3	10.3	13	13	17	19	19	
C	4.3	5.3	6.6	6.6	6.6	8.3	8.3	10.3	10.3	13	13	17	19	19	
E	1.0	1.3	2.2	2.2	2.2	3.1	3.1	4.5	4.5	4.4	4.4	6.4	6.4	6.4	
L	5.4	5.4	5.4	7.7	10.5	10.5	12.5	10.5	12.5	13.5	16.5	16.5	16.5	21.5	
H	0.5-0.8					0.8 ~ 1.1					1.1~1.4				

产品规格书 RUBYSUN PRODUCT SPECIFICATION

三、技术性能 Specifications

项目 Items	特性 Characteristics										
工作温度范围 Operating Temperature Range	-40°C ~ 105°C										
额定电压范围 Rated Voltage Range	4V ~ 100V										
标称电容量范围 Nominal Capacitance Range	0.1 ~ 8200 μF										
标称电容量允许偏差 Nominal Capacitance Tolerance	±20% (20°C, 120HZ)										
漏电流 Leakage Current	$I \leq 0.01C_R V_R$ or $3(\mu A)$, 取较大者 (施加额定电压 2 分钟) C_R : 标称电容量 (μF) U_R : 额定电压 (V) $I \leq 0.01C_R V_R$ or $3(\mu A)$ Whichever is greater (After 2 minutes' application of rated voltage C_R : Nominal Capacitance (μF) U_R : Rated voltages (V)										
损耗角正切 (tg δ) Dissipation Factor (Max) 20°C, 120HZ	U_R (V)	4	6.3	10	16	25	35	50	63	80	100
	tg δ	0.35	0.28	0.24	0.20	0.16	0.14	0.12	0.12	0.12	0.12
容量大于 1000uF 者, 每增加 1000uF, 其损耗角正切值增加 0.02 When nominal capacitance exceeds 1000uF, add 0.02 to the value above for each 1000uF increase											

产品规格书 RUBYSUN PRODUCT SPECIFICATION

四、标称电容量、额定电压、额定纹波电流与外形尺寸对应表

Nominal capacitance, rated voltage, rated ripple current and case size table

V	4		6.3		10		16		25		35		50	
μF	D×L mm	I~ mA	D×L mm	I~ mA	D×L mm	I~ mA	D×L mm	I~ mA	D×L mm	I~ mA	D×L mm	I~ mA	D×L mm	I~ mA
0.1													4×5.4	2.3
0.22													4×5.4	3.4
0.33													4×5.4	4.1
0.47													4×5.4	5
1.0													4×5.4	10
2.2													4×5.4	16
3.3											4×5.4	13	4×5.4	16
4.7									4×5.4	22	4×5.4	22	4×5.4	16
													5×5.4	23
10							4×5.4	28	4×5.4	22	4×5.4	22	5×5.4	25
													5×5.4	32
22			4×5.4	29	4×5.4	28	4×5.4	28	5×5.4	32	5×5.4	45	6.3×5.4	35
					5×5.4	30	5×5.4	39	6.3×5.4	55	6.3×5.4	60	6.3×7.7	51
33	4×5.4	31	4×5.4	30	4×5.4	29	5×5.4	35	5×5.4	35	6.3×5.4	60	6.3×7.7	70
			5×5.4	34	5×5.4	34			6.3×5.4	65				
47	4×5.4	31	4×5.4	32	4×5.4	30	5×5.4	45	5×5.4	35	6.3×5.4	65	6.3×7.7	80
			5×5.4	46	5×5.4	45	6.3×5.4	70	6.3×5.4	70	6.3×7.7	80		
68	4×5.4	35	5×5.4	46	5×5.4	46	6.3×5.4	70	6.3×5.4	70	6.3×7.7	80	6.3×7.7	80
100	5×5.4	55	5×5.4	52	5×5.4	50	6.3×5.4	70	6.3×5.4	70	6.3×7.7	90	8×10.5	230
			6.3×5.4	71	6.3×5.4	69	6.3×7.7	120	6.3×7.7	100	8×10.5	296		
150	6.3×5.4	95	6.3×5.4	90	6.3×5.4	70	6.3×7.7	120	8×10.5	280	8×10.5	300	10×10.5	300
220	6.3×5.4	100	6.3×5.4	95	6.3×5.4	95	6.3×7.7	120	6.3×7.7	120	8×10.5	320	10×10.5	375
			6.3×7.7	120	6.3×7.7	120			8×10.5	320	10×10.5	435		
330	6.3×7.7	140	6.3×7.7	130	6.3×7.7	130	8×10.5	305	8×10.5	320	10×10.5	450	10×10.5	400
			8×10.5	290	8×10.5	305			10×10.5	450			12.5×13.5	450
470	6.3×7.7	150	6.3×7.7	140	6.3×7.7	140	8×10.5	340	8×10.5	330	10×10.5	480	12.5×13.5	490
			8×10.5	330	8×10.5	340			10×10.5	490				
680	8×10.5	340	8×10.5	335	10×10.5	380	10×10.5	450	10×10.5	500	12.5×13.5	600	16×16.5	750
1000	8×10.5	350	8×10.5	340	8×10.5	350	10×10.5	550	12.5×13.5	550	16×16.5	800	18×16.5	990
					10×10.5	410			.5				.5	
1500	10×10.5	500	10×10.5	475	12.5×13.5	600	12.5×13.5	650	12.5×16.5	650	16×16.5	900		
					.5		.5		.5					
2200			12.5×13.5	680	12.5×13.5	680	16×16.5	900	16×16.5	900	18×16.5	1050		
			.5		.5									
3300			12.5×16.5	850	16×16.5	950	16×16.5	950	18×16.5	1150				
			.5							0				
4700			16×16.5	1000	16×16.5	1000	18×16.5	1225	18×21.5	1300				
				0		0		5		0				
6800			18×16.5	1290	18×16.5	1290								
				0		0								
8200			18×21.5	1450	18×21.5	1450								
				0		0								

产品规格书 RUBYSUN PRODUCT SPECIFICATION

V	63		80		100	
μF	D×L mm	I \sim mA	D×L mm	I \sim mA	D×L mm	I \sim mA
0.1	4×5.4	1.0				
0.22	4×5.4	2.3				
0.33	4×5.4	3.5				
0.47	4×5.4	5.0				
1.0	4×5.4	8			4×5.4	10
2.2	4×5.4	12			5×5.4	32
3.3	4×5.4	20			5×5.4	35
4.7	5×5.4	25			5×5.4	40
					6.3×5.4	45
10	6.3×5.4	42			6.3×7.7	60
22	6.3×7.7	50	8×10.5	100	8×10.5	80
33	8×10.5	90	8×10.5	100	8×10.5	90
47	8×10.5	100	10×10.5	150	8×10.5	100
					10×10.5	130
100	10×10.5	150	10×10.5	180	12.5×13.5	220
150	10×10.5	170	12.5×13.5	280	16×16.5	240
220	10×10.5	205	16×16.5	410	16×16.5	410
	12.5×13.5	250				
330	12.5×16.5	300	16×16.5	510	18×16.5	520
470	16×16.5	450	18×16.5	560		
680	18×16.5	600				
1000	18×21.5	800				

I=Rated ripple current (mA) (105°C, 120HZ) I=额定纹波电流 (mA) (105°C, 120HZ)

产品规格书 RUBYSUN PRODUCT SPECIFICATION

五、构造图及材料表 Frame drawing and materials

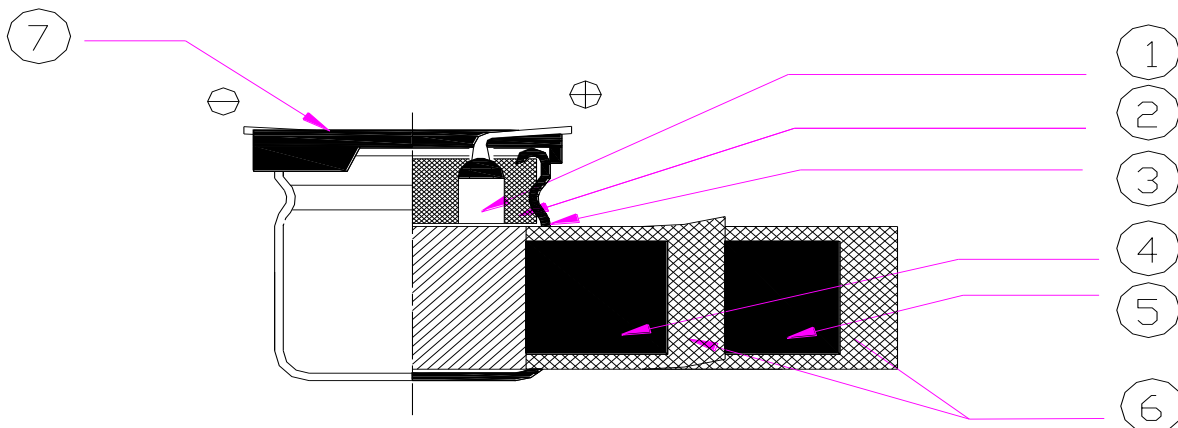

序号 No.	部件名称 Parts	材料名称 Material	主要供应厂家名称 Main supply Factory
1	引出线	铝线 LG3+镀锡铜钢线 AL- wire LG3+Tin- plating of copper cover steel	南通全用电子工业有限公司 NANTONG GENENIC ELECTRONIC INDUSTRY CO., LTD
2	橡胶塞	丁基橡胶 IIR rubber	苏州毅丰橡胶工业有限公司 YUFENG RUBBER INDUSTRY CO, LTD.
3	PE 铝壳 PE- CASE	99.5%纯度铝 AL - 99.5%	韶关源康机电有限公司 SHAOGUAN YUANKANG ELECTRICAL CO., LTD
4	阳极箔 AL - foil(+)	99.99%或 99.98%形成铝 箔 Formed AL 99.98% or 99.98%	杰希希电子科技(常熟)有限公司 JCC ELECTRONICS TECHNOLOGY (CHANGSHU) CO., LTD
5	阴极箔 AL - foil(-)	99.7%铝箔 Etched AL 99.7%	博罗冠业电子有限公司 AFT ELECTRONIC CO. LTD. BOLUO
6	电解纸 Separstor paper	电解电容器纸 Electrolytic Capacitor paper	上海铃茂新能源科技有限公司 (大福) DAI FUKU PAPER MFG. CO, LTD
7	座板 BASE	PPS	南通新联电子有限公司 NANTONG Xinlian ELECTRONIC CO. LTD.

产品规格书 RUBYSUN PRODUCT SPECIFICATION

六、 试验方法及要求 Tests

1	系列号(SERIES)	VT 系列(VT SERIES)											
2	额定电压 (rated voltage)	4~100V											
3	工作温度范围 Operating temperature range operating	工作温度范围是指电容器在额定电压下能持续工作的所允许外部环境的温度范围 operating temperature range is the range of ambient temperature at which the capacitor can be operated continuously at rated voltage SPEC:-40~+105℃											
4	电容容量 capacitance	测量等效电路图 measuring circuit equivalent series circuit											
		测量温度 20℃	measuring temperature										
		测量频率 120HZ	measuring frequency										
		测量电压 0.5Vrms	measuring voltage										
		标称电容容量允许偏差: ±20% MAX	Nominal Capacitance Tolerance: ±20% MAX										
5	损耗角正切 tangent of the loss angle	损耗角正切的测量应要和测量电容容量一样的条件下进行 Measurement should be made under the same conditions as those given for the measurement of capacitance SPEC:											
		损耗角正切 (tg δ)	U _R (V)	4	6.3	10	16	25	35	50	63	80	100
			tg δ	0.35	0.28	0.24	0.20	0.16	0.14	0.12	0.12	0.12	0.12
6	漏电流 leakage current	将额定电压加在电容和 1000±100Ω的保护电阻上。在充电 2 分钟后, 按下列等式计算漏电流 the rated voltage shall be applied across the capacitor and its protective resistor which shall be 1000±100Ω. The leakage current shall be then measured after an electrifications period of (A)min. The leakage current shall be calculated by the following equation 在加上额定电压一定时间后, 应满足下列要求: I≤0.01CV or 3μA Which is greater (取较大者) (20℃, 2 分钟) SPEC: The following specifications shall be satisfied when the rated voltage is applied for the required time.											
7	允许最大纹波电流 Maximum permissible ripple current	在规定的某一频率下的最大交流电流, 在该电流下电容器连续工作。即使在测过第 16 项下的耐久性后, 此要求仍要满足。在此, DC 电压加上最大纹波电压小于等于额定电压。 The maximum sinusoidal alternating current of a frequency specified below, at which the capacitor can be operated continuously. This requirement shall be satisfied even after the measurement of clause 16(electrical endurance) Where (DC voltage +peak ripple voltage) ≤rated voltage											

产品规格书 RUBYSUN PRODUCT SPECIFICATION

接上表

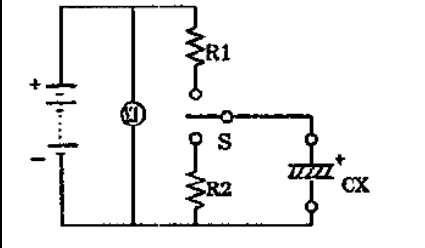
8	温度特性 Characteristics of temperature	<table border="1"> <thead> <tr> <th>步骤 step</th> <th>温度 temperature</th> <th>持续时间 Duration</th> </tr> </thead> <tbody> <tr> <td>1</td> <td>20±2°C</td> <td>15 分钟 15 min</td> </tr> <tr> <td>2</td> <td>最低工作温度 minimum operating temperature</td> <td>2 小时 2 hours</td> </tr> <tr> <td>3</td> <td>20±2°C</td> <td>15 分钟 15 min</td> </tr> <tr> <td>4</td> <td>最高工作温度 maximum operating temperature</td> <td>2 小时 2 hours</td> </tr> </tbody> </table> <p>步骤 1: 测量容量, 损耗角正切和阻抗 Step1: Capacitance, tangent of the loss angle impedance shall be measured.</p> <p>步骤 2: 在电容器存放 2 小时后, 测量容量, 损耗角正切和阻抗 Step2: After the capacitor being stored for 2hours, Capacitance, tangent of the loss angle and impedance shall be measured.</p> <p>步骤 3: 电容器在 20±2°C 下存放 15 分钟 Step3: The capacitor being stored fro 15min at20±2°C</p> <p>步骤 4: 在电容器存放 2 小时后, 测量容量和漏电流。 Step4: After the capacitor being stored for 2hours, capacitance and leakage current shall be measured</p> <table border="1"> <thead> <tr> <th>额定电压 rated voltage</th> <th>4</th> <th>6.3</th> <th>10</th> <th>16</th> <th>25</th> <th>35</th> <th>50</th> <th>63</th> <th>80</th> <th>100</th> </tr> </thead> <tbody> <tr> <td>Z-(-25°C/Z+20°C)</td> <td>7</td> <td>4</td> <td>3</td> <td>2</td> <td>2</td> <td>2</td> <td>2</td> <td>2</td> <td>2</td> <td>2</td> </tr> <tr> <td>Z-(-40°C/Z+20°C)</td> <td>15</td> <td>8</td> <td>6</td> <td>4</td> <td>4</td> <td>3</td> <td>3</td> <td>3</td> <td>3</td> <td>3</td> </tr> </tbody> </table>	步骤 step	温度 temperature	持续时间 Duration	1	20±2°C	15 分钟 15 min	2	最低工作温度 minimum operating temperature	2 小时 2 hours	3	20±2°C	15 分钟 15 min	4	最高工作温度 maximum operating temperature	2 小时 2 hours	额定电压 rated voltage	4	6.3	10	16	25	35	50	63	80	100	Z-(-25°C/Z+20°C)	7	4	3	2	2	2	2	2	2	2	Z-(-40°C/Z+20°C)	15	8	6	4	4	3	3	3	3	3
		步骤 step	温度 temperature	持续时间 Duration																																														
		1	20±2°C	15 分钟 15 min																																														
		2	最低工作温度 minimum operating temperature	2 小时 2 hours																																														
		3	20±2°C	15 分钟 15 min																																														
4	最高工作温度 maximum operating temperature	2 小时 2 hours																																																
额定电压 rated voltage	4	6.3	10	16	25	35	50	63	80	100																																								
Z-(-25°C/Z+20°C)	7	4	3	2	2	2	2	2	2	2																																								
Z-(-40°C/Z+20°C)	15	8	6	4	4	3	3	3	3	3																																								
9	浪涌测试 Surge test	<p>在规定温度下, 循环测试 1000 次, 每次充电 30±5 秒, 在放电大约 5 分 30 秒。在标准温度条件下存放使其稳定, 然后测试。 The capacitor shall be subjected to 1000cycles at a temperature specified below, each consisting of a charge period of 30±5sec, followed by a discharge period of approx. 5min30sec. And the capacitor shall be stored under standard conditions thermal to obtain stability, after which measurements shall be made.</p> <p>measurement circuit(测试电路图)</p>  <table border="1"> <tr> <td>VS: 浪涌电压 Surge voltage</td> <td>V1: 直流电压 DC voltmeter</td> </tr> <tr> <td>R1: 保护电阻 (1KΩ) Protective series resistor</td> <td>R2: 放电电阻器 Discharge resistor</td> </tr> <tr> <td>CX: 测试电容 Test capacitor</td> <td>S: 开关 Switch</td> </tr> </table> <p>SPEC: 1) $\Delta C/C \leq 15\%$ 2) $tg\delta <$ 规定值 3) 电压</p> <table border="1"> <thead> <tr> <th>RATED VOLTAGE (V_{DC})</th> <th>4</th> <th>6.3</th> <th>10</th> <th>16</th> <th>25</th> <th>35</th> <th>50</th> <th>63</th> <th>80</th> <th>100</th> </tr> </thead> <tbody> <tr> <td>SURGE VOLTAGE (V_{DC})</td> <td>5</td> <td>8</td> <td>13</td> <td>20</td> <td>32</td> <td>44</td> <td>63</td> <td>72</td> <td>92</td> <td>115</td> </tr> </tbody> </table>	VS: 浪涌电压 Surge voltage	V1: 直流电压 DC voltmeter	R1: 保护电阻 (1KΩ) Protective series resistor	R2: 放电电阻器 Discharge resistor	CX: 测试电容 Test capacitor	S: 开关 Switch	RATED VOLTAGE (V _{DC})	4	6.3	10	16	25	35	50	63	80	100	SURGE VOLTAGE (V _{DC})	5	8	13	20	32	44	63	72	92	115																				
		VS: 浪涌电压 Surge voltage	V1: 直流电压 DC voltmeter																																															
		R1: 保护电阻 (1KΩ) Protective series resistor	R2: 放电电阻器 Discharge resistor																																															
		CX: 测试电容 Test capacitor	S: 开关 Switch																																															
RATED VOLTAGE (V _{DC})	4	6.3	10	16	25	35	50	63	80	100																																								
SURGE VOLTAGE (V _{DC})	5	8	13	20	32	44	63	72	92	115																																								

产品规格书 RUBYSUN PRODUCT SPECIFICATION
接上表

10	端子强度 Terminal strength	<p>1) 拉力(tensile)</p> <table border="1" data-bbox="480 309 1461 483"> <thead> <tr> <th>d(mm)</th> <th>[N]</th> <th>Duration time</th> </tr> </thead> <tbody> <tr> <td>0.3<d≤0.5</td> <td>5</td> <td rowspan="3">10±2sec(秒)</td> </tr> <tr> <td>0.5<d≤0.8</td> <td>10</td> </tr> <tr> <td>0.8<d≤1.25</td> <td>20</td> </tr> </tbody> </table> <p>2) 抗弯强度 (Bending) 端子应该在每一方向上折弯一次，总共两次 The terminal shall be subjected to 1 bend in each direction to give a total 2 bends.</p> <table border="1" data-bbox="480 651 1461 824"> <thead> <tr> <th>d(mm)</th> <th>[N]</th> </tr> </thead> <tbody> <tr> <td>0.3<d≤0.5</td> <td>2.5 (0.25KG)</td> </tr> <tr> <td>0.5<d≤0.8</td> <td>5.0 (0.51KG)</td> </tr> <tr> <td>0.8<d≤1.25</td> <td>10.0(1.0KG)</td> </tr> </tbody> </table> <p>端子没有破损或松动 SPEC: No breaking and loosening of terminal</p>	d(mm)	[N]	Duration time	0.3<d≤0.5	5	10±2sec(秒)	0.5<d≤0.8	10	0.8<d≤1.25	20	d(mm)	[N]	0.3<d≤0.5	2.5 (0.25KG)	0.5<d≤0.8	5.0 (0.51KG)	0.8<d≤1.25	10.0(1.0KG)
d(mm)	[N]	Duration time																		
0.3<d≤0.5	5	10±2sec(秒)																		
0.5<d≤0.8	10																			
0.8<d≤1.25	20																			
d(mm)	[N]																			
0.3<d≤0.5	2.5 (0.25KG)																			
0.5<d≤0.8	5.0 (0.51KG)																			
0.8<d≤1.25	10.0(1.0KG)																			
11	可焊性 solderability	<p>焊料(Solder): H60A. H60S or(或)H63A 焊接温度(Solder temperature): 245±2℃ 浸入时间(Immersion time): 3±0.5sec(秒) 浸入深度(Immersion depth): 2mm 熔化: 松香在酒精的浓度是 25% Flux: 25% by weight of rosin in ethanol 从含浸处到顶部，至少要有 3/4 的部分覆盖有新焊料 SPEC:1)3/4 of the circumference of the surface up to the immersed shall be covered with new solder.</p>																		
12	耐焊接热 Resistance to soldering heat	<p>焊料(Solder): H60A. H60S or(或)H63A 焊槽温度(Solder temperature): 260±5℃ (or 或 350±10℃ 浸入时间(Immersion time): 10±1sec(秒) (or 或 3.5±0.5sec) 绝热屏蔽板的厚度 (Thickness of heat shunt:1.6mm): 1.6mm SPEC: 1) 电容量变化 Change in capacitance: ±10%初始值以内 Within±10% of the initial value 2) 损耗角正切 tangent of the loss angle: 小于等于初始规定值 The initial specified value or less 3) 漏电流 leakage current: 小于等于初始规定值 The initial specified value or less</p>																		
13	抗振性 Vibration	<p>试验电容器的耐振性。在整个频率范围内，从 10 赫兹到 55 赫兹，然后再返回到 10 赫兹，就这样在一分钟内往返循环。振幅为 1.5mm。在三个垂直方向上，每一方向要持续 2 小时，总共 6 小时 Only endurance conditioning by sweeping shall be made. The entire frequency range, from 10 to 55VT and return to 10VT, shall be transversed in 1min. Amplitude(total excursion)1.5mm, This motion shall be applied for a period of 2hours in each of3 mutually perpendicular directions(a total of 6 hours) SPEC:1) 电容量的变化(change in capacitance): ±5%初始值以内(within ±5%of the initial value) 2) 无可见损伤(No visible damage)</p>																		

产品规格书 RUBYSUN PRODUCT SPECIFICATION

接上表

<p>14</p>	<p>稳态湿热 Damp heat</p>	<p>电容器要在温度 $40\pm 2^{\circ}\text{C}$，相对湿度 90%到 95%条件下存放 500 ± 8 个小时。然后在标准条件下放 1 到 2 小时后进行测量。</p> <p>the capacitor shall be stored at a temperature of $40\pm 2^{\circ}\text{C}$ and relative humidity of 90 to 95% for 500 ± 8hours. And then the capacitor shall be subjected to standard atmospheric conditions for 1 to 2hours, after which measurements shall be made</p> <p>SPEC:1) 电容量的变化 change in capacitance: $\pm 15\%$初始值以内 within $\pm 15\%$of the initial value;</p> <p>2) 损耗角正切 tangent of loss angle: 小于等于初始规定值 The initial specified value or less;</p> <p>3) 漏电流 leakage current: 小于等于初始规定值 The initial specified value or less</p>
<p>15</p>	<p>高温储存 shelf life</p>	<p>在 105°C 温度下不外加电压贮存，电容器存放 1000 小时。然后在标准条件下放 1 到 2 小时后进行测量，并且在测漏电流前，必须满足下列条件。The capacitor shall be stored at 105°C temperature specified below for 1000hours. During which time no voltage shall be applied. And then the capacitor shall be subjected to standard atmospheric conditions for 1 to 2hours, after which measurements shall be made, Prior to the measurement of leakage current, following conditioning may be made. SPEC:</p> <p>1) 电容量的变化 change in capacitance: $\pm 20\%$初始值以内 within $\pm 20\%$of the initial value; ($\leq 16\text{V}$: $\pm 25\%$初始值以内) ($\leq 16\text{V}$: within $\pm 25\%$of the initial value);</p> <p>2) 损耗角正切 tangent of loss angle: $\pm 200\%$初始规定值以内 within $\pm 200\%$of the initial value;</p> <p>3) 漏电流 leakage current: 小于等于初始规定值 The initial specified value or less</p>
<p>16</p>	<p>耐久性 load life</p>	<p>在 $105\pm 2^{\circ}\text{C}$ 下，电容器加额定电压 1000 小时。在标准条件下放 1 到 2 小时后进行测量。</p> <p>The rated voltage shall be applied continuously to the capacitor at maximum operating temperature $105\pm 2^{\circ}\text{C}$ for 1000 hours. And then the capacitor shall be subjected to standard atmospheric conditions for 1 to 2hours, after which measurement shall be made. SPEC:</p> <p>1) 电容量的变化 change in capacitance: $\pm 20\%$初始值以内 within $\pm 20\%$of the initial value; ($\leq 16\text{V}$: $\pm 25\%$初始值以内) ($\leq 16\text{V}$: within $\pm 25\%$of the initial value);</p> <p>2) 损耗角正切 tangent of loss angle: $\pm 200\%$初始规定值以内 within $\pm 200\%$of the initial value;</p> <p>3) 漏电流 leakage current: 小于等于初始规定值 The initial specified value or less</p>

产品规格书 RUBYSUN PRODUCT SPECIFICATION

七、标志 Marking (见外形图及尺寸表)

说明：本产品规格书适用于深圳市玮硕实业有限公司生产的 VT 型片式铝电解电容器产品。

The product specification is adapted to series VT V-CHIP Aluminum Electrolytic Capacitors of Shenzhen Weishuo (Rubysun) Industrial Technology Co., Ltd.

1. 编带包装盘 REEL

单位 MM

ΦD×L	4×5.4	5×5.4	6.3×5.4	6.3×7.7	6.3*10.5	8×10.5	8×12.5	10×10.5	10×12.5	12.5×13.5	12.5×16.5	16×16.5	18×16.5	18×21.5
W	12.0	12.0	16.0	16.0	16.0	24.0	24.0	24.0	24.0	32.0	32.0	44.0	44.0	44.0
P	8.0	12.0	12.0	12.0	12.0	16.0	16.0	16.0	16.0	24.0	24.0	28.0	32.0	32.0
F	5.5	5.5	7.5	7.5	7.5	11.5	11.5	11.5	11.5	14.2	14.2	20.2	20.2	20.2
A ₀	5.0	6.0	7.0	7.0	7.0	8.7	8.7	10.7	10.7	13.2	13.2	17.5	19.5	19.5
B ₀	5.0	6.0	7.0	7.0	7.0	8.7	8.7	10.7	10.7	13.2	13.2	17.5	19.5	19.5
T ₂	5.8	5.8	5.8	8.0	11.0	11.0	13.3	11.0	13.3	14.3	17.3	17.3	17.8	22.5

八、片式铝电解电容的编带 V- Chip Type Aluminum Electrolytic Capacitors

φD	4	5	6.3 (8*6.5)	8	10	12.5	16	18
T	14	14	18	26	26	34	46	46

2. 包装数量 Package quantity

ΦD×L	Quantity / Reel 数量 / 每盘	pcs/ Small packing box 数量/小包装箱	pcs/Large packing box 数量/大包装箱
4×5.4	2000pcs	24000pcs	48000pcs
5×5.4	1000pcs	12000pcs	24000pcs
6.3×5.4、6.3×7.7、8×6.5	1000pcs	10000pcs	20000pcs
8×10.5、10×10.5	500pcs	3500pcs	7000pcs
6.3×10.5	800pcs	8000pcs	16000pcs
8×12.5	400pcs	2800pcs	5600pcs
10×12.5	400pcs	2800pcs	5600pcs
12.5×13.5	200pcs	1200pcs	2400pcs
12.5×16.5	150pcs	900pcs	1800pcs
16×16.5	125pcs	625pcs	1250pcs
18×16.5	125pcs	625pcs	1250pcs
18×21.5	75pcs	375pcs	750pcs

产品

规格书 RUBYSUN PRODUCT SPECIFICATION

九、环保 ROHS



检测报告

编号: SZXEC24001596302

日期: 2024 年 05 月 24 日

第 1 页, 共 8 页

客户名称: 深圳市玮硕实业有限公司

客户地址: 深圳市龙华区观澜章阁市场尚之佳工业园 A 栋 3 楼

样品名称: 铝电解电容器
型号: VT
客户参考信息: RVT VD CK CS JVD LHI LHD UT LHT
以上样品及信息由客户提供。

SGS 工作编号: SZP24-021847
样品接收时间: 2024 年 05 月 21 日
检测周期: 2024 年 05 月 21 日 ~ 2024 年 05 月 24 日
检测要求: 根据客户要求检测
检测方法: 见后续页。
检测结果: 见后续页。

检测要求	结论
铅、汞、镉、六价铬、多溴联苯 (PBB)、多溴二苯醚 (PBDE)、邻苯二甲酸二(2-乙基己基)酯 (DEHP)、邻苯二甲酸丁苄酯 (BBP)、邻苯二甲酸二丁酯 (DBP)和邻苯二甲酸二异丁酯 (DIBP)	见检测结果



检测报告

编号: SZXEC24001596302

日期: 2024 年 05 月 24 日

第 8 页, 共 8 页

样品照片:



此照片仅限于随 SGS 正本报告使用
报告结束